

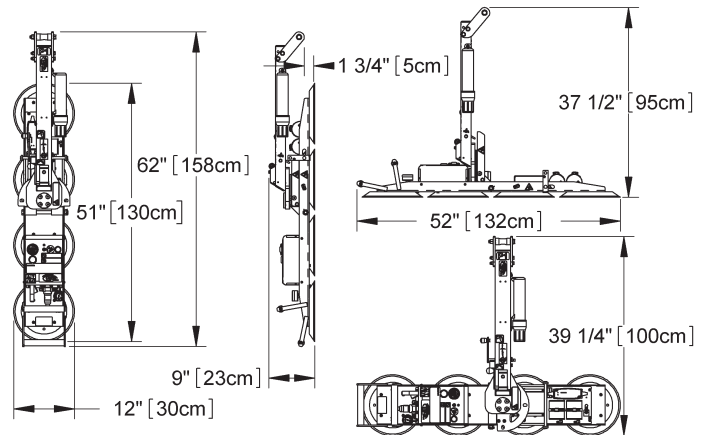

WOOD'S POWR-GRIP® CHANNEL LIFTERS P1 ORIGINAL EDITION

In addition to a modular design, these Powr-Grip® vacuum lifters provide 180° rotation and 90° tilt, for expandability and a full range of load motion at the installation site or on the shop floor.



P11104DC
(For flat materials)
700 lbs [320 kg]

P11004DC
(For curved materials)
600 lbs [270 kg]

P110T04DCO
(For rough materials)
600 lbs [270 kg]

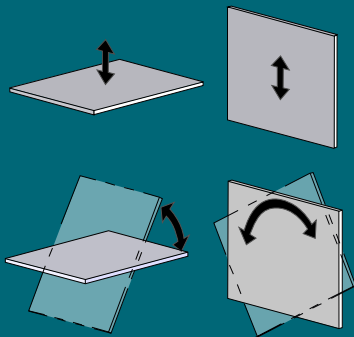

**THE ORIGINAL
& TRUSTED NAME
IN VACUUM LIFTING
EQUIPMENT**

**800.548.7341
WPG.com**

908 West Main - P.O. Box 368
Laurel, Montana 59044 U.S.A.
406.628.8231 (phone)
406.628.8354 (fax)

Maximum Load Capacity	P11104DC: 700 lbs [320 kg] P11004DC*: 600 lbs [270 kg] P110T04DCO: 600 lbs [270 kg] <small>(*Capacity is reduced on curved surfaces. Please contact us for more information.)</small>
Load Movement	Manual rotation, 180° edgewise, with locking at each 1/4 turn Manual tilt, 90° between upright and flat, with automatic latching in upright position (in center rotation position, as shown on drawings)
Standard Operating Power	12 volts DC, 10 amps (for each Pad Channel)
Standard Features	Adjustable-position lift spool Battery and charger Battery energy gauge Low vacuum warning light Vacuum gauge Vacuum line filter Vacuum reserve tank
Available Options	Dual vacuum system (P1-04DC3) ABS shipping case (53005) (see page 2 for more information) Counterbalance Lifter (CB2DCS)
Alternate Power System	Air (venturi) power system (P1-04AIRS) <small>(Specifications may not be as listed above. Please contact us for more information.)</small>
Lifter Weight	90 lbs [41 kg]
Standard Pad Spread	P11104DC: 51" x 12" [130 x 30 cm] P11004DC: 49" x 10" [125 x 25 cm] P110T04DCO: 50¾" x 11¾" [129 x 30 cm]
Number / Size of Pads	P11104DC: 4 / 11" [28 cm] dia. lipped P11004DC: 4 / 10" [25 cm] dia. concave P110T04DCO: 4 / 10" [25 cm] dia. with replaceable sealing rings
Design Standards	ASME B30.20 (BTH-1 Design Category "B", Service Class "0") AS 4991 <small>(See www.WPG.com for more information.)</small>

Based on product information at time of publication. Environmental conditions can affect product performance and longevity; consult the product instructions on WPG.com or contact a Technical Sales Representative for more information.

Channel Lifters are comprised of one or more Pad Channels and interchangeable Lift Frames for manually rotating and tilting materials. They may be ordered as complete units or as individual components to expand existing Channel Lifter systems. Lift Frames are available in single-channel or double-channel styles. Pad Channels can be switched from one frame to another in minutes.

COMPONENTS:

Pad Channels

Each channel features an independent, vacuum generating system, including vacuum pump, vacuum controls and standard features as listed on page 1.

PC1104DC: (for flat materials) 4 / 11" [28 cm] dia. lipped pads (94110, 94111, 94112)

PC1004DCO: (for curved materials) 4 / 10" [25 cm] dia. concave pads (special order)

PC10T04DCS: (for rough materials) 4 / 10" [25 cm] dia. pads with replaceable sealing rings (special order)

Lift Frames

PCFT1A1: For one Pad Channel (94154)

PCFT2SA45: For two Pad Channels, approx. 4½' [1.38 m] pad spread (94165)

PCFT2SA7: For two Pad Channels, approx. 7' [2.14 m] pad spread (94170)

Interchangeable Arms

(Pad spread can be changed if optional arms are purchased)

FA245: Optional arms convert PCFT2SA7 Lift Frame to PCFT2SA45 Lift Frame (57222AM)

FA27: Optional arms convert PCFT2SA45 Lift Frame to PCFT2SA7 Lift Frame (57223AM)



SHIPPING CASE FOR P1 VACUUM LIFTERS

(lifter and case sold separately)

Designed specifically for shipping and storing all Powr-Grip® P1-04 Series Vacuum Lifters.

Durable thermo-formed ABS construction.

Three straps on inside of case hold vacuum lifter firmly in place.

Eight plastic buckles attached to nylon straps hold case in closed position.

Handles molded into the case structure enable convenient handling.

Ribbed exterior of case enables easy stacking of multiple lifters.

Case design incorporates grooves on the bottom to facilitate forklift handling.