



FIVE STAR PRODUCTS, INC.

www.fivestarprom.com
(800) 243-2206

DESIGN-A-SPEC™ GUIDELINES FIVE STAR STRUCTURAL CONCRETE ES

CONTENTS

▶	PART A - GENERAL CONDITIONS
▶	PART B - MATERIAL SPECIFICATIONS
▶	PART C - PREPARATION
▶	PART D - APPLICATION
▶	PART E - FINISHING AND CURING
▶	PART F - EXTREME WEATHER CONDITIONS

This document is provided for informational purposes only and as a general guideline for consideration by contractors and engineers. While every reasonable effort has been made to ensure that this information is accurate and authoritative, Five Star Products does not warrant the accuracy or completeness of this information, or for its appropriateness for any particular purpose. The user of this document remains solely responsible for the specification of all methods, materials and practices.

PART A - GENERAL CONDITIONS - CONCRETE REPAIR

1.01 SCOPE

The work covered by this document consists of furnishing all equipment, materials, labor and performing all operations required for concrete repairs as directed by the engineer or owner.

1.02 QUALITY ASSURANCE

- A. The manufacturer shall have been in the business of manufacturing similar products for over ten years, maintain a strict quality assurance program, offer technical services and provide a representative at the jobsite for product training, prior to product installation, upon written request.
- B. The contractor shall submit to the engineer, or owner, at least three job references where the contractor has successfully completed similar applications.

1.03 DELIVERY, STORAGE AND HANDLING

- A. All materials shall be delivered to the jobsite in their original, unopened packages, clearly labeled with the manufacturer's identification, printed instructions and batch code.
- B. Store and condition the specified product as per the appropriate product data sheet.
- C. For handling instructions, refer to the Material Safety Data Sheet.

1.04 PROJECT/SITE CONDITIONS

Refer to PART C - PREPARATION, ENVIRONMENTAL CONDITIONS, or contact the manufacturer directly for any physical or environmental limitations required by the product.

1.05 MEASUREMENT AND PAYMENT

- A. Measurement for concrete repairs shall be on a cubic foot/square foot (liter/square meter) basis of material in place.
- B. Payment for concrete repairs shall be at the unit price bid on a cubic foot/square foot (liter/square meter) basis. This payment shall constitute full compensation for all labor, materials, tools, equipment and other items as necessary to complete the work as described in the contract documents. Progress payments will be made on the percentage of the work satisfactorily completed during each payment period in accordance with the provisions of the contract documents.

PART B - MATERIAL SPECIFICATION - CONCRETE REPAIR

2.01 MATERIALS

A. The concrete repair material shall be an extended set, pre-packaged cement-based mortar requiring only the addition of potable water. The material shall not contain any chlorides or lime other than amounts contained within the hydraulic cement composition. The manufacturer shall be ISO 9001 certified and have at least ten years experience in the manufacture of concrete repair materials. The manufacturer shall offer technical services and provide a representative at the jobsite for product training prior to product installation upon five days advance notice.

B. The concrete repair material shall meet all the following typical performance criteria when cured at 73°F (23°C):

1.	Compressive Strength, ASTM C 109	
	6 Hours	3,000 psi (20.7 MPa)
	1 Day	5,000 psi (34.5 MPa)
	7 Days	6,000 psi (41.4 MPa)
2.	Bond Strength, ASTM C 882	
	1 Day	2,000 psi (13.8 MPa)
3.	Length Change, ASTM C 157	
	28 Days Wet	+0.03%
	28 Days Dry	-0.05%
4.	Chloride Ion Permeability, ASTM C 1202	
	3 Days	Very Low
5.	Coefficient of Thermal Expansion, ASTM C 531	
		5.0 x 10 ⁻⁶ in/in/°F (9.0 x 10 ⁻⁶ mm/mm/°C)

The data shown above reflect typical results based on laboratory testing under controlled conditions. Reasonable variations from the data shown above may result in the field. Test methods are modified where applicable.

C. An acceptable product that meets these criteria is:

Five Star Structural Concrete® ES

As manufactured by Five Star Products, Inc., Fairfield, CT 06824 (203) 336-7900.

- D. Subject to meeting the performance criteria stated above, other products may be formally submitted to the engineer for approval up to three days prior to the bid date. All requests for approval shall contain certified test data verifying conformance with this specification. Three references of successfully completed projects of similar nature and scope of the work detailed in this specification shall be provided, as well as a minimum ten year history of use in the industry. The testing laboratory shall certify to any modifications made to the tests performed and provide details of modifications.

2.02 AGGREGATE EXTENSION

- A. For pours greater than two cubic feet (56.5 liters) in volume, the concrete repair material may be extended by the addition of clean, damp, coarse aggregate according to the following guidelines:

<u>Depth of Pour</u> Inches (mm)	<u>Typical Extension</u> (Percentage by wt.)
Up to 2 (up to 50)	-0-
2+ – 6 (50 – 150)	50%
6+ – 9 (150 – 225)	60%
9+ – 12 (225 – 300)	80%
Greater than 12 (300)	CONTACT MANUFACTURER

Coarse aggregate shall conform to the requirements of ASTM C 33. Maximum size of coarse aggregate shall not be greater than one-third the depth of the repair. Aggregate samples may be submitted for approval.

PART C – PREPARATION - CONCRETE REPAIR

3.01 CONCRETE SURFACES

- A. Completely remove all loose, delaminated and weak concrete, oil, grease, laitance and other contaminants. Prepare concrete using acceptable mechanical means to obtain clean, sound and rough surfaces. Mechanically roughen concrete surfaces to an ICRI (International Concrete Repair Institute Technical Guideline 03732) Concrete Surface Profile of 6 or greater. Coarse aggregate shall be exposed. Blow out concrete surfaces using oil free compressed air to remove all dust, debris and other contaminants.
- B. The edges of the repair shall be vertical and have a rough profile. Avoid abrupt changes in depth.
[The minimum repair depth specified should be determined by the product selected, the maximum size of aggregate, and the nature of the repair.]
- C. For formed vertical and overhead repairs with a depth greater than one inch (25 mm), mechanical anchors may be provided.
- D. The perimeter of the repair shall be kept to a simple shape. Avoid reentrant corners.

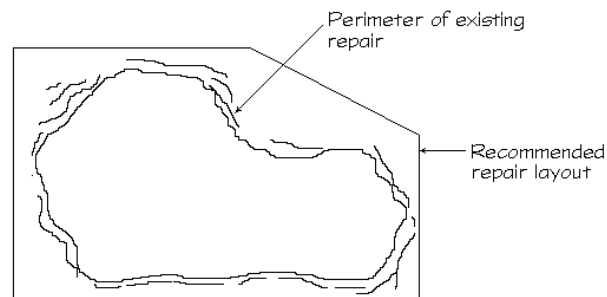

- E. All cracks shall be brought to the attention of the engineer and a determination made of whether the cracks are subject to movement. The cracks shall be repaired as directed prior to application of the repair material.
- F. All existing joints shall be maintained. New joints, if any, shall be installed as detailed on the drawings.
- G. Soak concrete thoroughly with potable water prior to placement. Concrete shall be saturated and free of standing water at time of placement. An epoxy bonding agent may be used in lieu of presoaking. Apply epoxy bonding agent uniformly in accordance with manufacturer's recommendations.
[For more detailed information, refer to the following source: "Surface Preparation Guidelines For The Repair of Deteriorated Concrete Resulting From Reinforcing Steel Oxidation", Report of International Concrete Repair Institute, March 1995.]

3.02 REINFORCEMENT

- A. All reinforcing steel that has lost bond with the concrete or has more than one-half of its circumference exposed shall be undercut by at least 3/4 inch (18 mm) or two times the maximum aggregate size.

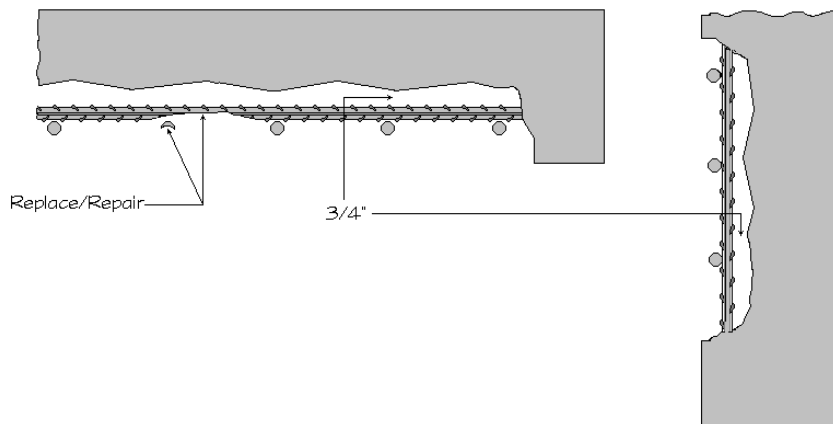

- B. All reinforcement shall be rigidly secured and supported.
- C. If more than 20% of the diameter of a reinforcing bar has been deteriorated, the bar will require replacement or will need to be spliced as directed by the engineer.
- D. All exposed reinforcing steel shall be free of all loose scale and rust, and other contaminants.
- E. The minimum cover over reinforcement shall be in accordance with job specifications or 2 inches (25 mm), whichever is greater.

3.03 FORMWORK

- A. Formwork shall be constructed of rigid nonabsorbent materials, securely anchored, watertight and strong enough to resist forces developed during placement.
- B. Formwork shall be coated with a form release agent.
Caution: Care should be taken not to contaminate concrete surfaces where bond is required.
- C. Provide air relief holes as necessary.
- D. Ports shall be provided as necessary for the installation of repair material, venting and/or monitoring progress of placement. Quick acting valves or other means of sealing ports shall be provided.

3.04 ENVIRONMENTAL CONDITIONS

- A. Condition and maintain all materials and surfaces that contact repair material to between 35°F and 90°F (2°C and 32°C), but optimally between 55°F and 75°F (13°C and 24°C) whenever possible. Shade from direct sunlight as necessary. *[When faster strength gain is required at low temperatures, or longer working time is required at high temperatures, revise the temperature range above as appropriate and refer to detailed conditioning procedures for Cold Weather or Hot Weather Repairs, PART F – EXTREME WEATHER CONDITIONS.]*

3.05 EQUIPMENT AND MATERIALS

- A. All necessary tools, equipment and materials shall be in good condition and as close as possible to area being repaired.
- B. Appropriate clothing and safety equipment shall be worn to avoid breathing dust and prevent eye and skin contact with both dry and mixed repair materials.
- C. An ample source of potable water shall be available for preconditioning, mixing, cleaning and curing.

3.06 MIXING

[Select one of the following types of mixers, as appropriate.]

Mortar Mixer (Stationary Barrel with Moving Paddles)

- A. Provide an adequate number of mortar mixers in good operating condition for uninterrupted placement. Do not exceed one-half the maximum capacity of the mortar mixer.
- B. Pre-wet mortar mixer, empty excess water.
- C. Start by adding the minimum amount of premeasured potable water to mixer. While mixing, slowly add repair material and mix to a uniform consistency.
- D. Mix thoroughly for approximately five minutes. To achieve desired consistency, add remaining water as necessary. Do not exceed maximum water content as stated on product packaging or an amount that will cause segregation.
- E. Do not mix more material than can be placed within the working time of the repair material. Do not retemper the mix by adding additional water.
- F. For pours requiring aggregate extension, add clean, damp coarse aggregate meeting the requirements of ASTM C 33 before final water adjustment.

* *Concrete mixers are acceptable when extending Structural Concrete ES with coarse aggregate. Add premeasured water and coarse aggregate to mixer first followed by Structural Concrete ES.*

Drill and Paddle Mixer

- A. Start by adding the minimum amount of premeasured potable water into large pail or wheelbarrow. While mixing at a slow speed, slowly add repair material and mix to a uniform consistency. Add remaining water to achieve desired consistency. Do not exceed maximum water content as stated on product packaging or an amount that will cause segregation.
- B. Continue to mix thoroughly for approximately five minutes.
- C. Do not mix more material than can be placed within the working time of the repair material. Do not retemper the mix by adding additional water.

Ready-Mix Concrete Truck – Bulk Bags + Coarse Aggregate Extension

- A. **Verify working time of repair material and required water addition under jobsite conditions before placement in concrete truck.**
Caution: Failure to do so may result in material setting up in truck.
- B. Mixing drum and mixing blades must be in good operating condition, predampened and excess water removed.
- C. First add clean, damp, coarse aggregate meeting the requirements of ASTM C 33 to drum.
- D. Add approximately 90% of premeasured potable water to mixing drum as determined by testing. Five gallons of this 90% shall be held back for hopper wash down. Water addition must be adjusted if wet aggregate is used or water is present in drum.
- E. Add repair material, with drum turning at a slow speed. Do not exceed half the capacity of drum or add more than three bulk bags per truck. Use the 5 gallons (19 liters) of held back water to wash down hopper and drum after loading. Mix thoroughly for approximately five minutes at slow speed to a uniform consistency.
- F. Reverse drum to check consistency. Add remaining water as needed and mix to a uniform consistency. Do not exceed maximum allowable water content as stated on product packaging or add an amount that will cause segregation. Small bags of product should be available to stiffen consistency, if necessary.
- G. Position truck as close as possible to pour and promptly discharge from truck.

PART D – APPLICATION - CONCRETE REPAIR

4.01 PLACEMENT PROCEDURES

[Select one or more of the following methods as appropriate.]

FORM AND POUR

[For large vertical and horizontal repairs.]

- A. Chutes, tremies, buggies, buckets or similar equipment may be required for material placement. Provide adequate access to allow a vibrator to be inserted into repair material for consolidation. Where this is not possible, vibrate formwork. Only use vibration when necessary. Use vibrator in a manner to avoid material segregation. Vibrators shall not be used to move repair material laterally.
- B. For vertical repairs, material shall be poured in formwork in a manner to avoid segregation. Do not allow material to fall freely over reinforcement or other embedded materials.
- C. For horizontal repairs, firmly work repair material into roughened substrate to completely fill all pores and voids. Material shall be poured continuously from one side of repair area to the other starting at the lowest elevation. When placing in layers on large pours, each horizontal layer shall extend repair width. Placement must be continuous to prevent cold joints. Place and consolidate in a manner to avoid segregation.
- D. Continue placement until repair area is completely filled.
[For more recommended placement information, refer to ACI 304R-89, Guide for Measuring, Mixing, Transporting and Placing Concrete.]

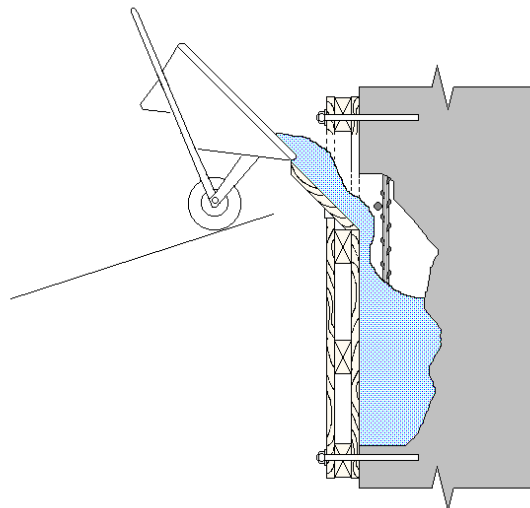

REFERENCE

ACI 304R-89

"Guide for Measuring, Mixing, Transporting and Placing Concrete"

FORM AND PUMP

[For large vertical and overhead repairs with closely spaced reinforcement.]

- A. The pump type, size and discharge line used are dependent on the installation parameters. The minimum inside diameter of the discharge line shall be three times greater than the maximum aggregate size. Contact pump and material manufacturers for recommendations. The proposed pumping equipment and procedures shall be submitted for approval.
- B. Pumping raises the material temperature and shortens the working time while reducing consistency. Keep mix temperature as cool as necessary, except in cold weather.
- C. The repair material shall be mixed to a consistency that will not segregate while pumping.
- D. The repair material shall pass through an appropriate size screen during placement into pump hopper.
- E. Before pumping, determine working time of material under jobsite conditions. Pumpability shall be determined by field testing.
- F. The pump shall be positioned to minimize pumping distance.
- G. Immediately prior to pumping, the pump and lines shall be primed with a slurry of repair material without coarse aggregate until the hopper is empty. Caution: All repair materials are not compatible with portland cement slurries. Mix slurry to a consistency that will not segregate in the pump or lines.
- H. Once pumping has begun, it is important not to use any of the priming slurry from the discharge lines. Pumped material shall not be used until a uniform consistency is obtained at the discharge nozzle.
- I. Provide adequate volume of mixed material to keep pump hopper at least half full. The material shall be placed into pump hopper in a manner to prevent air entrapment and segregation.
- J. Once form is filled and all vent ports are closed, increase line pressure additional 5 psi (0.03 MPa) and stop pumping. Close off formwork inlet port.
- K. Remove formwork when appropriate.

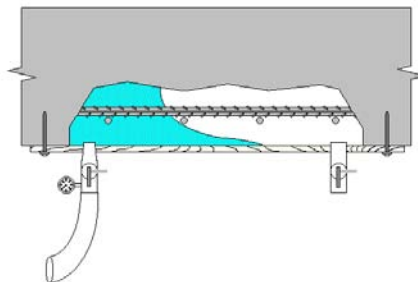

REFERENCE

ACI 304.2R-91
 "Placing Concrete by Pumping Method"

TROWEL - HORIZONTAL

[For horizontal repair areas with limited reinforcement.]

- A. Substrate shall be saturated and free of standing water or bonding adhesive shall be tacky during application.
- B. Firmly work repair material into roughened substrate completely filling all pores and voids. Whenever possible, place repair material full depth from one side of the repair to the other. Where this is not practical, placement shall be continuous to prevent cold joints.
- C. Once desired level is achieved, screed repair material and finish to desired texture.

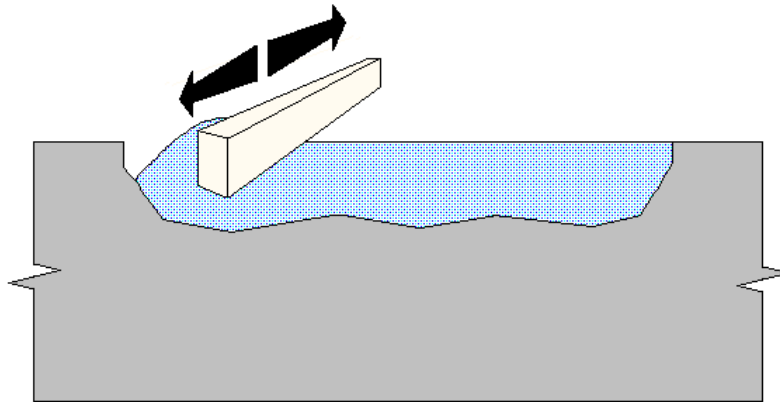

PART D – APPLICATION - CONCRETE REPAIR

4.01 PLACEMENT PROCEDURES OVERLAYS

- A. Substrate shall be saturated and free of standing water or bonding adhesive shall be tacky during application.
- B. When bonding adhesive is not used, firmly work repair material into substrate to completely fill all pores and voids. Uniformly place overlay material in front of screed to a slightly overfilled elevation. Level and consolidate by screeding.
- C. Placement shall be continuous to prevent cold joints.

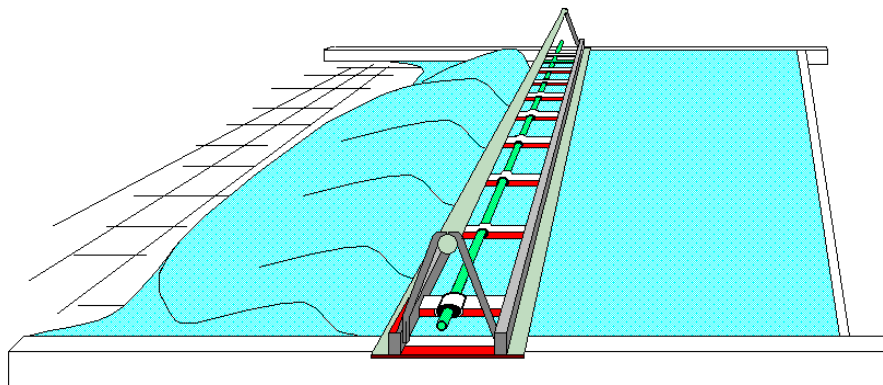
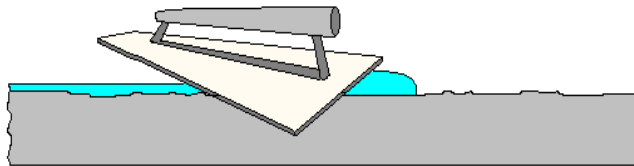

PART E – FINISHING AND CURING - CONCRETE REPAIR

5.01 FINISHING

[The surface texture may be modified by form liners, grinding or application of a coating.]

5.02 CURING

- A. Repair material shall be cured as recommended by the manufacturer.
- B. Repair material shall be protected from freezing, hydrostatic pressure and vibration as recommended by the manufacturer.

PART F – EXTREME WEATHER CONDITIONS - CONCRETE REPAIR

6.01 COLD WEATHER REPAIRS

[Low temperatures delay the set, increase working time and delay the strength development of cement-based products. The procedures below will compensate for these conditions.]

- A. All surfaces shall be preconditioned and maintained between 35°F and 90°F (2°C and 32°C) and materials conditioned to between 35°F and 80°F (2°C and 27°C). Higher substrate and material mix temperatures will result in faster strength development. Due to the mass of palletized material and bulk packaging, up to 72 hours of conditioning may be required. Presoak area with hot water where applicable.
- B. Heating the repair area shall be accomplished by indirect exposure. Heated enclosures must be windproof and weatherproof. Combustion heaters must be vented and shall not be permitted to heat and dry the concrete locally. *Caution: Exhaust gases may contaminate or cause carbonation within the enclosed environment. Ensure repair material does not dry out during heating.*
- C. Maintain temperature above 35°F (2°C) minimum until material reaches 1000 psi (6.9 MPa) or the minimum required strength.
[Specify minimum required strength.]
- D. Gradually allow temperature of material to cool to ambient temperature to avoid thermal shock.

REFERENCE

ACI 306R-88
"Cold Weather Concreting"

PART F – EXTREME WEATHER CONDITIONS - CONCRETE REPAIR

6.01 HOT WEATHER REPAIRS

[High temperatures accelerate the set, decrease working time, and accelerate the strength gain of cement-based products. The procedures below will compensate for these conditions.]

- A. Materials shall be conditioned as necessary so that the mixed material is between 50°F and 90°F (10°C and 32°C). Due to the mass of palletized material and bulk packaging, up to 72 hours of conditioning may be required.
- B. All surfaces in contact with material must be preconditioned and maintained below 90°F (32°C).
- C. Cooling of surfaces, materials and equipment can be accomplished by using iced water for mixing and presoaking concrete. Do not put ice directly into repair material. Shade area from direct sunlight or pour material when temperatures are decreasing.
- D. Wind breaks shall be provided when necessary to prevent rapid evaporation.
- E. Repair material shall remain protected and curing shall be dependent on specified product. Cure repair material in accordance with manufacturer's recommendations. *[Specify appropriate curing method.]*

REFERENCE

ACI 305R-91
"Hot Weather Concreting"